

KLT-B4K-OV5648 V2.0**OmniVision OV5648 MIPI Interface Fixed Focus 5MP Camera Module**

Camera Module No.	KLT-B4K-OV5648 V2.0
Image Sensor	OV5648
EFL	2.37 mm
F.NO	2.4
Pixel	2592 X 1944
View Angle	87.8°
Lens Type	1/4 inch
Lens Dimensions	6.5 x 6.5 x 3.92 mm
Module Type	Fixed Focus
Interface	MIPI

Mating Connector Part No. 24-5804-024-000-829

Mating Connector On Main Board. Sold Separately.



OV5648 5-megapixel product brief



Cost-Efficient 5-Megapixel Camera Solution for Mainstream Mobile Devices



available in a lead-free package

The OV5648 is a cost-efficient, high performance 5-megapixel CameraChip™ sensor for smartphones and tablets. Utilizing OmniVision's latest 1.4-micron OmniBSI+™ pixel architecture, the OV5648 combines a reduced die size with improved quality photography and high-definition (HD) video, making it ideally suited for mainstream mobile applications.

OmniVision's powerful new OmniBSI+ pixel architecture offers significant performance improvements over our original OmniBSI™ architecture, including a 60 percent increase in full-well capacity and a significant improvement in low-light sensitivity. With OmniBSI+, the 1/4-inch OV5648 is capable of capturing high quality still images as well as 720p HD video at 60 frames per second (fps) and 1080p HD video at 30 fps.

The sensor supports a two-lane MIPI interface, and provides full-frame, windowed or binned 10-bit images in RAW RGB format with complete user control over

formatting and output transfer. It offers defective pixel canceling and all required automatic image control functions, including automatic exposure control, automatic gain control, automatic white balance, and automatic black level calibration.

A secondary image sensor may be connected to the OV5648 enabling a Video-in-Video (ViV) feature in which the secondary image is overlaid to the OV5648 output video. The combined video is streamed out over the MIPI interface. A bypass mode allows a secondary sensor to utilize the OV5648 MIPI interfaced baseband.

The OV5648 can fit into a 6 x 6 mm fixed focus camera module with a z-height of less than 4.5 mm.

Find out more at www.ovt.com.

Applications

- Cellular and Picture Phones
- PC Multimedia
- Toys
- Digital Still Cameras

Product Features

- 1.4 μm x 1.4 μm pixel with OmniBSI™ technology for high performance (high sensitivity, low crosstalk, low noise)
- optical size of 1/4"
- automatic image control functions:
 - automatic exposure control (AEC)
 - automatic gain control (AGC)
 - automatic white balance (AWB)
 - automatic black level calibration (ABLC)
- programmable controls for frame rate, AEC/AGC 16-zone size/position/weight control, mirror and flip, cropping, windowing, and panning
- defective pixel canceling
- support for output formats: 8-/10-bit raw RGB data
- support for video or snapshot operations
- support for LED and flash strobe mode
- support for internal and external frame synchronization for frame exposure mode
- support for horizontal and vertical sub-sampling
- standard serial SCCB interface
- MIPI interface (two lanes)
- Video-in-Video (ViV) and bypass support for secondary sensor
- 32 bytes of embedded one-time programmable (OTP) memory
- on-chip phase lock loop (PLL)
- embedded 1.5V regulator for core power
- programmable I/O drive capability, I/O tri-state configurability
- support for black sun cancellation

OV5648

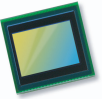

Ordering Information

- OV05648-A53A**
(color, lead-free, 53-pin CSP3)
- OV05648-G04A**
(color, chip-probing, 200 μm backgridding, reconstructed wafer)

Product Specifications

- active array size:** 2592 x 1944
- power supply:**
 - core: 1.5V \pm 5% (with embedded 1.5V regulator)
 - analog: 2.6 - 3.0V (2.8V typical)
 - I/O: 1.7 - 3.0V
- power requirements:**
 - active: 219 mW
 - standby: 36 μ W
- temperature range:**
 - operating: -30°C to 70°C junction temperature
 - stable image: 0°C to 50°C junction temperature
- output formats:** 8-/10-bit RGB RAW output
- lens size:** 1/4"
- lens chief ray angle:** 29.1°
- input clock frequency:** 6 - 27 MHz
- max S/N ratio:** 36 dB
- dynamic range:** 72 dB @ 8x gain
- maximum image transfer rate:**
 - QSXGA (2592x1944): 15 fps
 - 1080p: 30 fps
 - 960p: 45 fps
 - 720p: 60 fps
 - VGA (640x480): 90 fps
- sensitivity:** 690 mV/lux-sec
- shutter:** rolling shutter
- pixel size:** 1.4 μm x 1.4 μm
- dark current:** 0.7 mV/s @ 50°C junction temperature
- image area:** 3673.6 μm x 2738.4 μm
- package/die dimensions:**
 - CSP3: 5010 μm x 4810 μm
 - COB: 5000 μm x 4800 μm

Functional Block Diagram

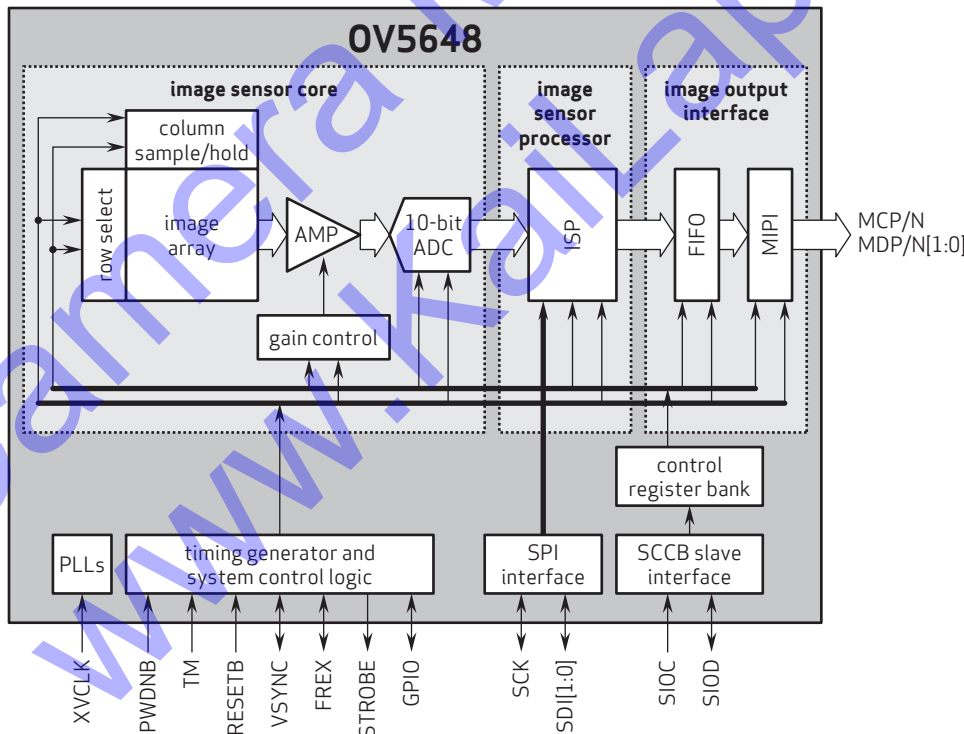

4275 Burton Drive
Santa Clara, CA 95054
USA

Tel: +1 408 567 3000
Fax: +1 408 567 3001
www.ovt.com

OmniVision reserves the right to make changes to their products or to discontinue any product or service without further notice. OmniVision, the OmniVision logo and VarioPixel are registered trademarks of OmniVision Technologies, Inc. CameraChip and OmniBSI+ are trademarks of OmniVision Technologies, Inc. All other trademarks are the property of their respective owners.

OmniVision